

**For Surface Mount Installations**

**STEP 1**

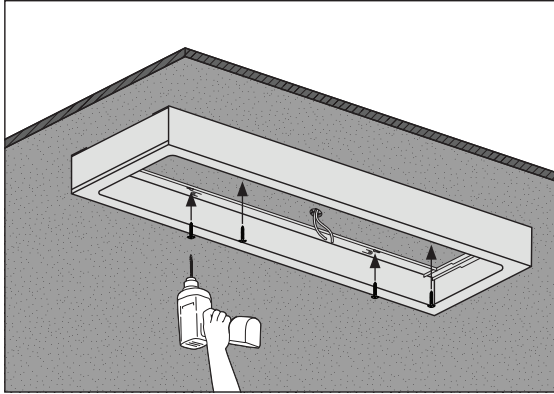

Switch off mains power.  
Fix frame to ceiling via four surface mount holes.

**STEP 2**

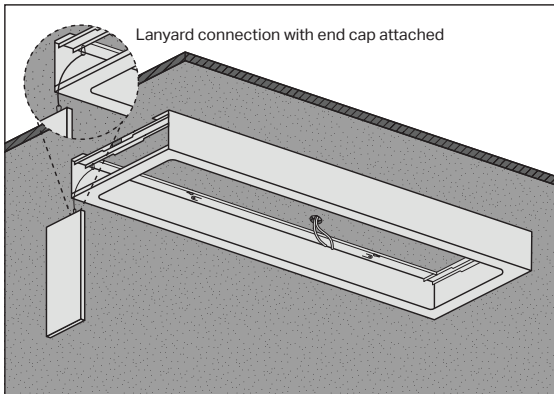

Remove one end cap on either side of the frame by pushing the end cap from the inside.  
Lift out the end cap and let the end cap hang with the connected lanyard.

**STEP 3**

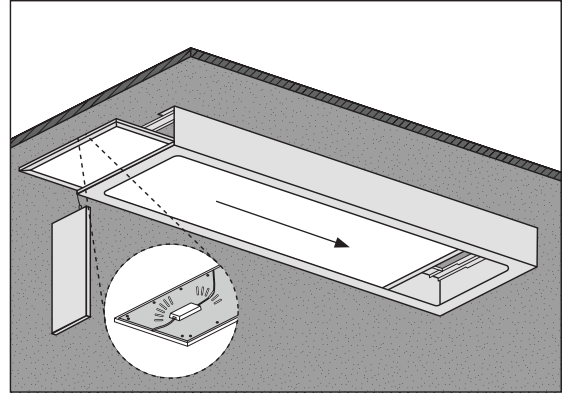

Connect luminaire to power supply by following **luminaire's installation instructions**.  
Slide the luminaire into the frame.

**STEP 4**

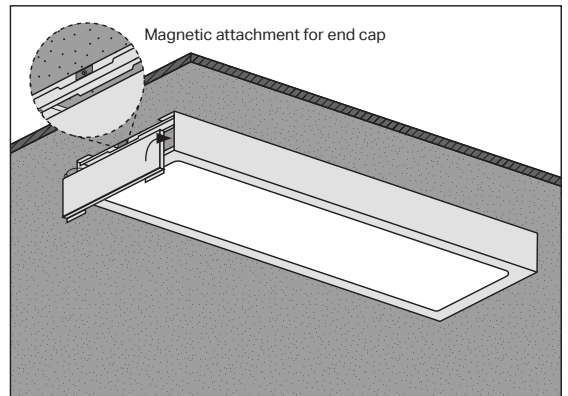

Attach the end cap back into place

**STEP 5**

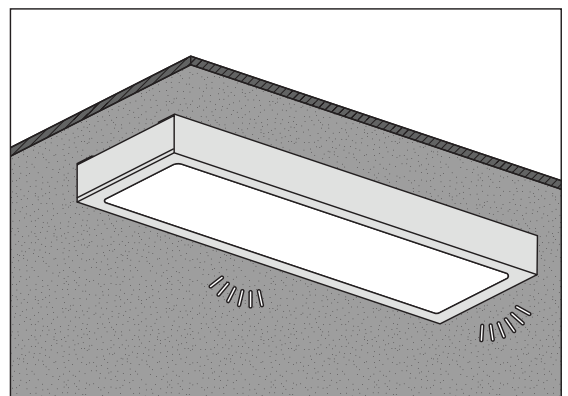

Switch on mains power

### For Suspended Installations

**STEP 1**

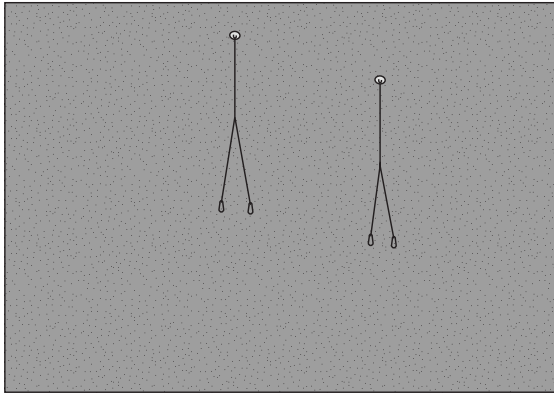

Switch off mains power.  
Fix suspension kit to ceiling. (Suspension kit not included).

**STEP 2**

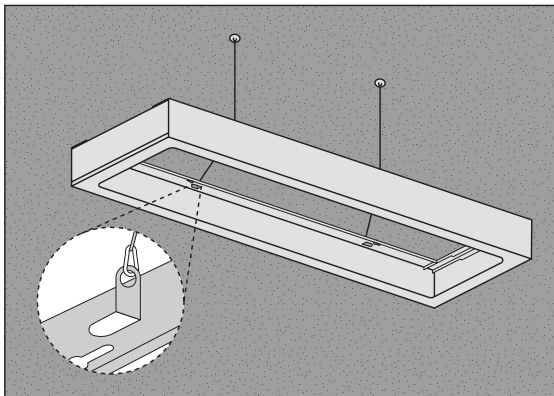

Bend the four frame suspension hole attachments to 90 degrees.  
Attach frame to the suspension kit via four suspension holes.

**STEP 3**



Remove one end cap on either side of the frame by pushing the end cap from the inside.

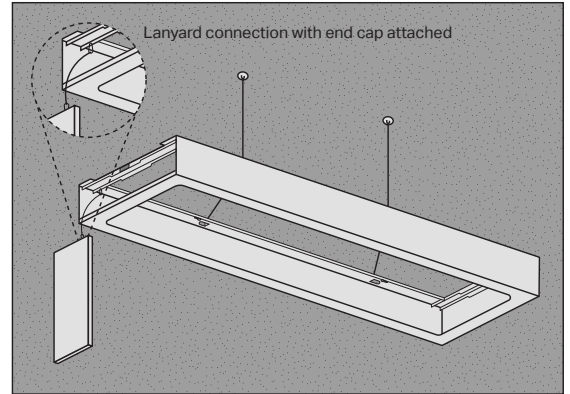

Lift out the end cap and let the end cap hang with the connected lanyard.

**STEP 4**

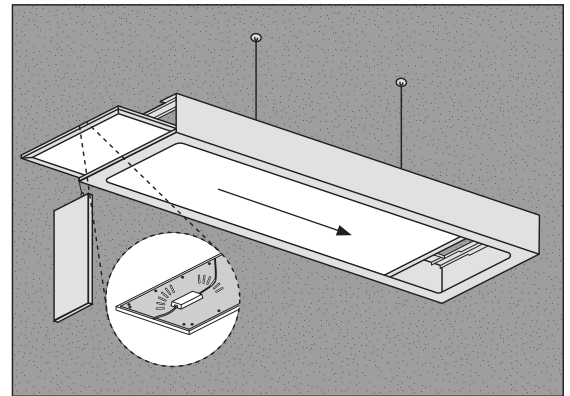

Connect luminaire to power supply by following **luminaire's installation instructions**.  
Slide the luminaire into the frame.

**STEP 5**

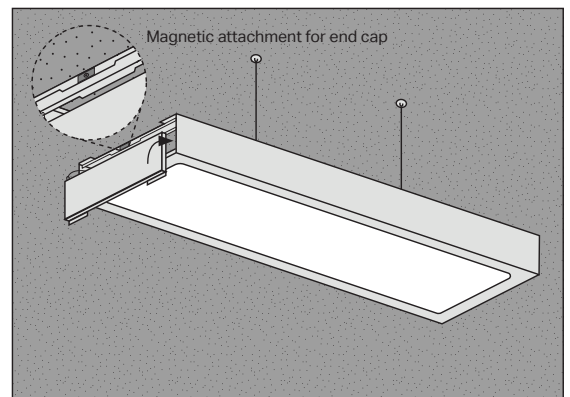

Attach the end cap back into place.

**For Suspended Installations**

**STEP**  
**6**

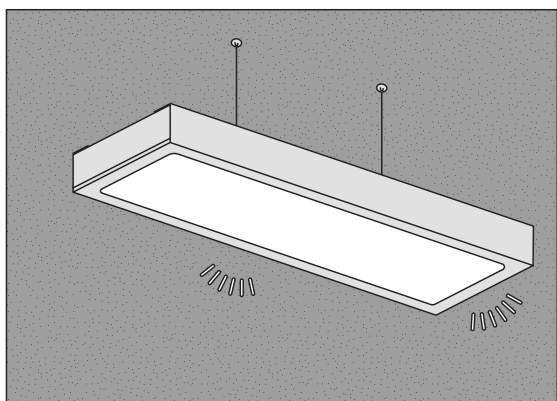

Switch on mains power.

**INSTALLATION & WARRANTY INSTRUCTIONS**

14 Oct 2020

**PRODUCT BRAND** PIERLITE  
**PRODUCT NAME** UNIVERSAL SURFACE MOUNT & SUSPENDED FRAME  
**CODES** SMFRM063, SMFRM066, SMFRM123, SMFRM126

**PLEASE READ THESE INSTALLATION INSTRUCTIONS CAREFULLY BEFORE INSTALLING OR MAINTAINING THIS EQUIPMENT. THE PRODUCT IS DESIGNED FOR INSTALLATION AND MAINTENANCE IN ACCORDANCE WITH RELEVANT STANDARDS (AS/NZS 3000) AND LOCAL REGULATIONS (WHERE APPLICABLE), BY AN AUTHORISED AND LICENCED ELECTRICIAN.** THE INSTALLATION INSTRUCTIONS WERE CORRECT AT THE TIME OF PRINT. TO REFLECT CHANGES IN TECHNOLOGY AND STANDARDS; PIERLITE RESERVES THE RIGHT TO AMEND THE INSTRUCTIONS WITHOUT NOTICE. UPDATED GUIDELINES CAN BE FOUND ON THE RELEVANT BRAND WEBSITE.

**IMPORTANT** - THE PRODUCT MUST BE MAINTAINED AND OPERATED IN ACCORDANCE WITH THE MANUFACTURER'S INSTRUCTIONS, FAILURE TO DO SO MAY DAMAGE THE PRODUCT AND SERVICES. IT IS STRONGLY RECOMMENDED THAT THIS IMPORTANT NOTE BE COMMUNICATED TO THE OWNER AND OR OPERATOR OF THE INSTALLATION AT THE TIME OF SITE COMMISSIONING. GOOD PRACTICE DOES NOT RECOMMEND THE 24/7 USE OF PRODUCTS WITHOUT THE APPLICATION OF SUITABLE SWITCH CYCLE INTERVALS. FURTHERMORE, WITH THE OMISSION OF NOMINATED SURVIVAL CURVES AND OR RECOMMENDED OPERATING HOURS, PRODUCT DESIGN EXPECTATIONS PROVIDE FOR A CONTINUAL DAILY USAGE OF 6 HOURS FOR RESIDENTIAL APPLICATIONS AND A CONTINUAL DAILY USAGE OF 12 HOURS FOR COMMERCIAL AND INDUSTRIAL APPLICATIONS. ALL PRODUCTS MUST BE THOROUGHLY CLEANED ON A REGULAR BASIS AT INTERVALS THAT REFLECT IN THE INSTALLATION ENVIRONMENT, ENSURING THE OPTICAL PERFORMANCE, TOGETHER WITH THE ELECTRICAL, MECHANICAL AND STRUCTURAL INTEGRITY AS DESIGNED, IS MAINTAINED THROUGHOUT THE SERVICE LIFE OF THE PRODUCT.



**1. PRODUCT SPECIFICATION:**

Product Code	Description	Dimension	Net Weight
SMFRM063	Universal Surface Mount & Suspended Frame 600x300	619x300x108	2.7kg
SMFRM066	Universal Surface Mount & Suspended Frame 600x600	619x600x108	3.1kg
SMFRM123	Universal Surface Mount & Suspended Frame 1200x300	1219x300x108	3.4kg
SMFRM126	Universal Surface Mount & Suspended Frame 1200x600	1219x600x108	4.4kg

**2. APPROVALS:** The RCM marking of this product applies to AS/NZS CISPR15 (EMC) "Limits and methods of measurement of radio disturbance characteristics of electrical lighting and similar equipment". This product is designed to conform to AS/NZS 60598 "Luminaires, general requirements and tests".



**3. STORAGE:** Prior to installation products are to be stored in cool and dry conditions.

**4. APPLICATION:** The installation application and orientation of the product is designed in accordance with the nominated product IP rating, class designation and these installation instructions. Installation environments and operating conditions beyond these instructions are not recommended.

**5. INSTALLATION / GENERAL:** Installation of the product is to be completed by an authorized and licensed electrician, in accordance with these instructions, relevant standards and local regulations (where applicable). Termination of product wiring, together with the installation of the product must be in a manner and orientation that maintains the integrity of the designated IP rating of the product For electronic control equipment (when supplied) DO NOT MEGGER between A and N.

**6. INSTALLATION / SPECIAL CONDITIONS** (relevant only for products approved for such an installation):

**(a) products installed in high wind environments** must have suitable installation / fastening methods applied to ensure the product's mounting points are not damaged through, corrosion, constant vibration and or movement. Exterior products are designed with precise vertical aiming limits, which should not be exceeded. Any vertical floodlight aiming requirements should be specifically validated in writing with the relevant brand before consideration.

**(b) products installed in corrosive or salt laden environments** require special consideration and such; specific product selection, inclusive of suitable fastening methods and extensive ongoing maintenance of products installed in these environments require professional advice. It is essential that all aspects of the product selection, material specification and maintenance are specifically designed for such use and a cleaning program be adopted that maintains the design integrity of the product.

**(c) interior highbay products** must be vertically suspended. The method of suspension (chain etc) must be able to support at least 5 times the total weight of the fitting. Do not install where air movement will cause the fitting to swing about, causing wear and tear of attachment points. Luminaires should be installed where access for maintenance is practical and allows for maintenance to be completed in accordance with the manufacturer's recommendations.

**(d) interior (downlight) products** must be installed to ensure the lamp unit or the driver (if supplied) are not covered with any combustible materials or insulation; minimum spacings nominated for these materials are mandatory. Unless otherwise specified, minimum clearances are in accordance with AS/NZS 3000 requirements. The product is not designed for installation environments which restrict conventional airflow movements eg: enclosed boxes or concrete profiles. For dimming purposes please see the relevant product brand web site for the dimming compatibility chart. When mounting multiple fixtures to conductive structures, it is recommended that the structure is earthed. The mounting facilities provided for the transformer/driver (if any), need only be utilized if in the application of the product is required by AS/NZS 3000. IP ratings stated (if any) are from below the ceiling unless stated otherwise and the installation of the product must be in a manner that maintains the integrity of the relevant IP rating.

**7. MAINTENANCE:**

**(a)** The supply must be isolated before opening or accessing the luminaire. Product maintenance is IMPORTANT and is critical to the products designed performance. The product is to be maintained in accordance with the manufacturer's instructions. For the latest product maintenance guides please go to relevant brand web site. Pierlite is not responsible for any product not maintained in accordance with the recommended procedure or intervals.

**(b) lamps (where provided):** The product is designed with the supplied LEDs/LAMP and it is strongly recommended that any LEDs/LAMP changes (if any) be made in accordance with the type, colour and brand supplied. For recommended LEDs/LAMP maintenance or operating guides (inclusive of recommended product switch cycles and mandatory run-in procedures for HID and Fluorescent lamps when used with dimming circuits), Pierlite recommends the application of the lamp manufacturer's operating guidelines, which can be found on manufacturer's website. Pierlite is not responsible for the product performance of alternative LEDs/LAMP used. As a member of FluroCycle, we encourage recycling of lamps and components.

**(c) battery (where provided):** The battery is designed with a rated average battery design life of 25,000 hours in standby mode. The battery is supported with a standard 3 year warranty; conditional of the product being maintained and operated in accordance with the manufacturer's guidelines and tested in accordance with AS/NZS 2293. For guidelines see product installation instructions or visit the relevant brand web site.

**(d) for products supplied with glass visors or covers,** do not operate the product with a damaged visor or cover; it is recommended the product be turned off, area surrounding the product vacated and the damaged glass replaced by a professional installer immediately.

**8. WARRANTY INSTRUCTIONS:** For the purpose of warranty claims (if any) the following instructions apply:

**Warranty components** - THE PRODUCT, (identified as the THE PRODUCT only). **Warranty period** - The above components are provided with a warranty of THREE (3) year/s or 15,000 hours of operation (which ever arrives first) against manufacturing defects or failure to perform to specifications for products installed by an authorised installer in accordance with the manufacturer's installation instructions and which have not been subject to incorrect operation or maintenance, unauthorised modification or damage arising from any intervening cause. **Warranty reference** - The warranty reference date commences from the date of purchase. **Warranty point of contact** - 0508 743 754 | [www.pierlite.co.nz](http://www.pierlite.co.nz) Pierlite New Zealand. **Warranty claim procedure** - For the purpose of making a claim the customer must: 1. Contact the "point of contact" above and upon provision of proof of purchase the customer will receive a goods return advice (GRA) number. 2. At the customer's expense, collect and return the goods to the "point of contact" with the issued GRA number. 3. Upon receipt of the goods, Pierlite will review the claim and if found to be accepted, Pierlite will return a replacement product to the customer to install at the customer's expense. Alternatively if the claim is rejected, the customer may request the return of the goods at their expense.

**Consumer Contracts** - The benefits to the customer given by the Pierlite warranty are in addition to other rights and remedies of the customer if the goods are the subject of a Consumer Contract under the Consumer Law. In that event the following statement is required to be brought to the Consumer's attention:- *Our goods come with guarantees that cannot be excluded under the Consumer Law. You are entitled to a replacement or refund for a major failure and for compensation for any other reasonably foreseeable loss or damage. You are also entitled to have the goods repaired or replaced if the goods fail to be of acceptable quality and the failure does not amount to a major failure.* **Limitation of Liability** - if the goods are not purchased by the customer under a Consumer Contract within the Consumer Law then but not otherwise;- (a) the Company is not liable in tort for any loss or damage suffered by the customer or by any third party; and (b) in no circumstances is Pierlite liable to the customer or to any third party for any loss of profits, loss of anticipated savings, economic loss or interruption of business or for any indirect or consequential loss (Consequential Loss). **Terms of Sale** - these Warranty provisions are in substitution for any inconsistent provisions in the Pierlite Terms and Conditions of Sale in so far as they apply to the Warranty components.

## INSTALLATION INSTRUCTIONS

### For Surface Mount Installations

- Step 1: Switch off mains power.
- Step 2: Fix frame to ceiling via four surface mount holes.
- Step 3: Remove one end cap on either side of the frame.
- Step 4: Connect luminaire to power supply by following luminaire's installation instructions.
- Step 5: Slide the luminaire into the frame.
- Step 6: Attach the end cap back into place.
- Step 7: Switch on mains power.

### For Suspended Installations

- Step 1: Switch off mains power.
- Step 2: Fix suspension kit to ceiling. (suspension kit not included)
- Step 3: Attach frame to the suspension kit via four suspension holes.
- Step 4: Remove one end cap on either side of the frame.
- Step 5: Slide the luminaire into the frame.
- Step 6: Attach the end cap back into place.
- Step 7: Connect luminaire to power supply by following luminaire's installation instructions.
- Step 8: Switch on mains power.

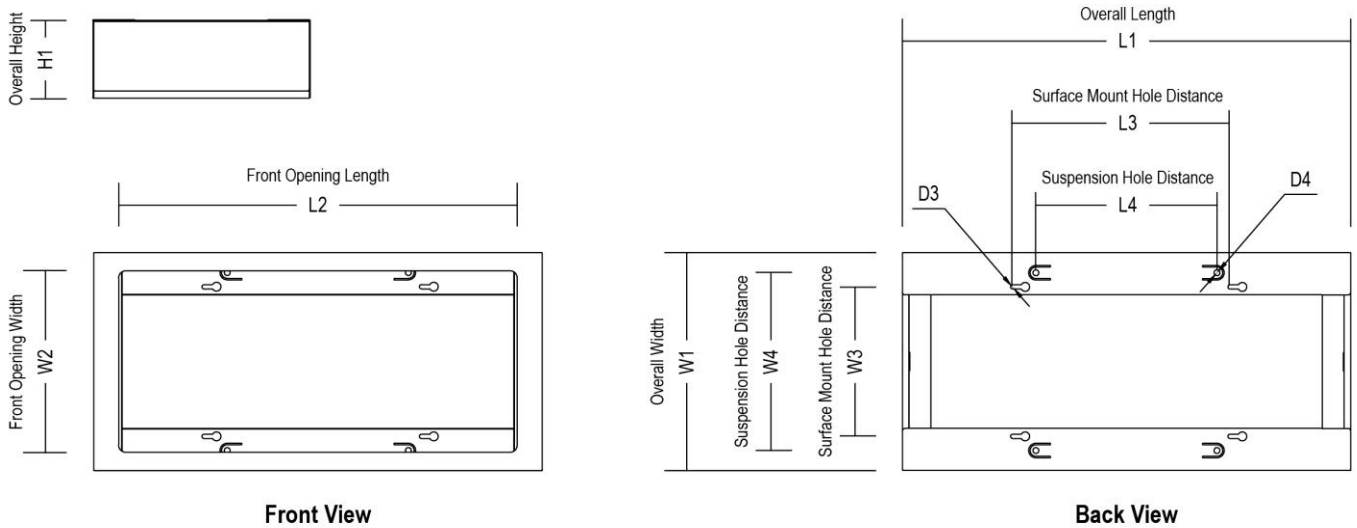

Product Code	L1	W1	H1	L2	W2	L3	W3	D3	L4	W4	D4
SMFRM063	619	300	108	550	250	300	206	6	210	245	8
SMFRM066	619	600	108	550	550	300	506	6	210	545	8
SMFRM123	1219	300	108	1150	250	900	206	6	810	245	8
SMFRM126	1219	600	108	1150	550	900	506	6	810	545	8